

# Service Manual for Hydraulic Cylinder

RA 17 038-DT1SM/06.09 1/8  
Replaces: 10.07

Model CDT1/CGT1

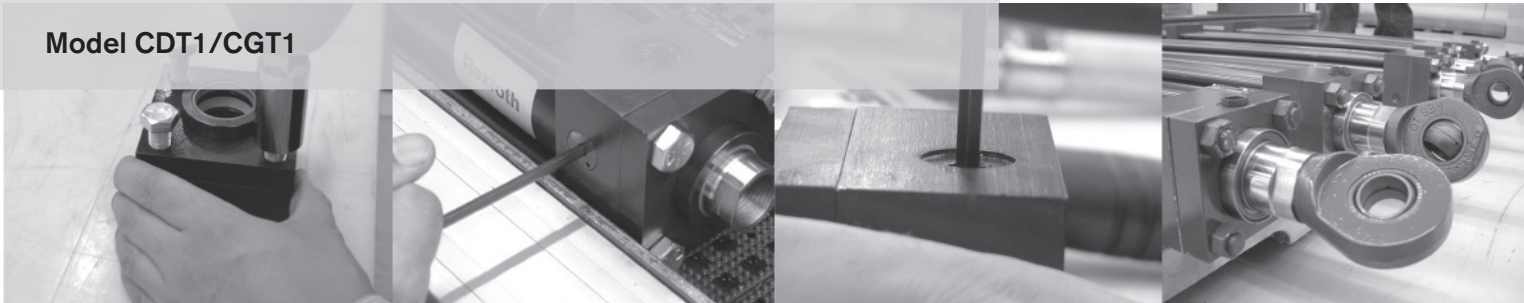

## Table of contents

Seal Replacement	
General	2
Old Rod Cartridge Kit Removal	2
New Rod Cartridge Kit Installation	2
Piston Seal Installation	2
Exploded View Drawing	3
Weights and Torque Values	3
End Cap Seal Installation	4
Testing	5
Spare Parts	6-8

## Seal Replacement

### General:

1. Always drain the pressure from a hydraulic system before performing any service work. Disconnect hydraulic lines from head and cap ports of cylinder.
2. Completely disassemble the cylinder using the exploded and assembly views as reference. No special tools are required except internal snap ring pliers. The piston rod assembly consisting of piston, piston rod and head cushion bushing (where used) are locktited and secured at the factory and are not to be disassembled.
3. After disassembling the cylinder, wash all metal parts in a non-flammable solvent. Rinse each part thoroughly and blow dry with a low-pressure air jet. Arrange the parts on a clean surface. Examine each part carefully. Replace all seals and any other worn or damaged parts.
4. Particular attention should be given to the piston rod (item 10) since cylinder leakage can result from a damaged rod. A scored rod might damage the rod bearing and, subsequently, the rod packing. Rod cartridge kits come with a new rod bearing plus seals (see Seal Kit table on page 6 of this manual.)

### Old Rod Cartridge Kit Removal

1. Remove the hex head bolts (item 15) from the head end (item 1).
2. Remove the retainer plate or flange (item 5) from the head end. Locate the screwdriver slot along the top of the rod bearing (item 16). Using a flathead screwdriver, carefully pry the rod cartridge loose from the head in a fashion similar to opening a can of paint. The rod bearing assembly includes the wiper (item 19a), the rod seal (item 19b), the bearing o-ring and backup ring (items 19c-d), and the rod bearing (item 16) itself.



### New Rod Cartridge Kit Installation:

1. Lubricating the new rod bearing will ease installation into the head end. A rubber mallet may be required to push the rod bearing into the head end. Caution must be taken to not cut the new seals when passing the bearing over a male threaded rod.

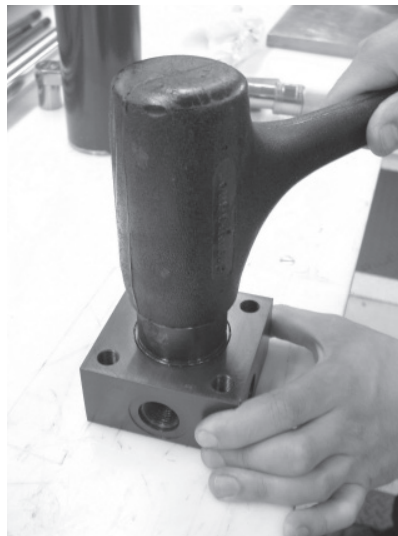

2. Once the rod bearing is completely seated in the head end, the flange or retainer plate and tie rod nuts / hex head cap screws can be replaced onto the head end. Torque the bolts / screws to the specifications on page 3.

### Piston Seal Installation:

1. Insert the energized piston seal o-ring onto the piston in the center groove. Do not roll the o-ring; rather, slide it into place. Slide piston seal into the center groove, directly over top of the o-ring. Heating the piston seal in 175°F to 212°F warm oil or water would assist in installation by hand. While still warm, the piston seal can be reshaped by means of a ring compressor or other aid.



Exploded View Drawing

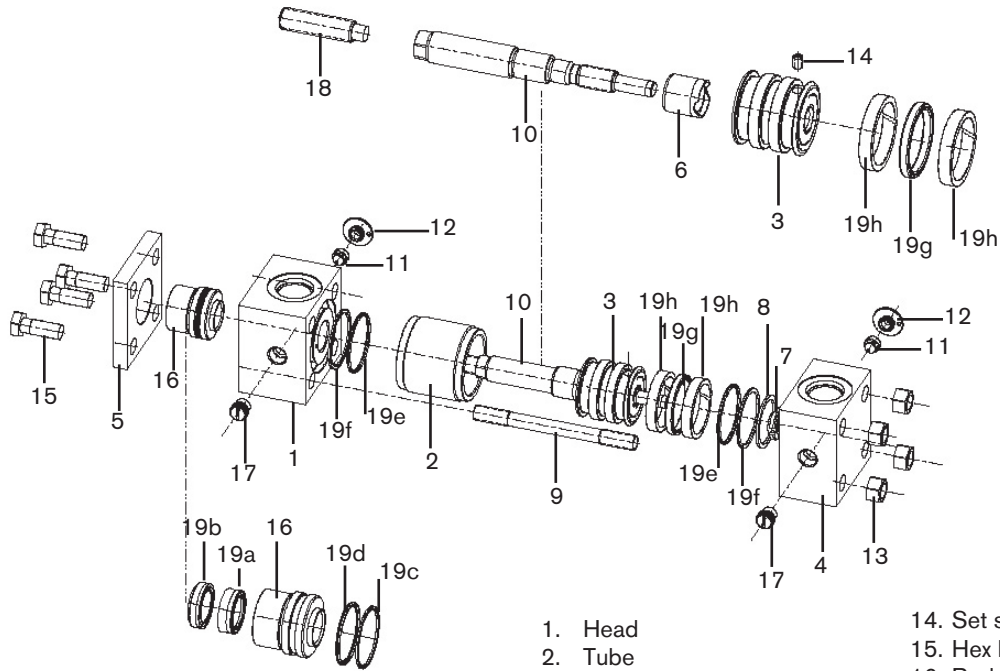

- 1. Head
- 2. Tube
- 3. Piston
- 4. Cap
- 5. Flange
- 6. Cushion bushing
- 7. Cushion insert
- 8. Cushion insert retainer ring
- 9. Tie rod
- 10. Piston rod
- 11. Bleed screw
- 12. Securing plate
- 13. Tie rod nut
- 14. Set screw
- 15. Hex head bolt
- 16. Rod bearing
- 17. Cushion valve
- 18. Threaded stud
- 19. Seals
  - a. Wiper
  - b. Rod seal
  - c. Bearing o-ring
  - d. Bearing backup ring
  - e. Tube o-ring
  - f. Tube backup ring
  - g. Piston seal
  - h. Wear bands

CDT1 Weight/Torque Values

Approx. Uncrated CDT1 Hyd. Cyl. Weights (lbs.)		
Bore Size (inches)	Zero Stroke	Add Per Inch of Stroke
1.00	3	0.2
1.50	5	0.3
2.00	7	0.4
2.50	12	0.6
3.25	20	0.8
4.00	30	0.9
5.00	45	1.0
6.00	70	1.5
8.00	100	2.0

Tie Rod Nuts and Bolts		
Bore Size (inches)	Tie Rod Threads	Torque Lubricated (pound-ft)
1.000	10 - 24	2
1.500	1/4 - 28	4.5
2.000	5/16 - 24	9
2.500	5/16 - 24	12
3.250	3/8 - 24	22
4.000	3/8 - 24	22
5.000	1/2 - 20	45
6.000	1/2 - 20	45
8.000	5/8 - 18	90

Socket Head Cap Screw (all 8" bore sizes)		
Rod Size	SHCS Size	Torque Lubricated (pound-ft)
All	1/2 - 13	74

\* Note: Weights are based upon a standard rod diameter. With multiple rod sizes and mounting options available, these weights may vary.

## Seal Replacement - continued

2. Install the split wear bands (item 19h) onto the piston in the outer grooves.

### End Cap Seal Installation:

1. Install the backup ring (item 19f) by pulling it over the face lip (head and cap ends). Be sure the groove of the backup ring is facing forward (barrel side). Do not drag the o-ring (item 19e) over the face, this will twist the o-ring; rather, pull the o-ring over the face lip, making sure it is against the groove of the backup ring.



2. Lubricate the chamfer ends and ID of the tube. Line up the cap end to be perpendicular with the tube. A twisting movement might be necessary to seat the cap end against the tube. Caution must be taken not to cut the o-ring.

3. Lubricate the piston seal and guide rings. Install the piston and rod assembly into the tube by applying force to the end of the piston rod. With the aid of a ring compressor, this will allow the rod assembly to seat itself into the cylinder tube.

4. After the piston and rod assembly is completely bottomed against the cap end, lubricate the top of the piston rod wrench flats. This will assist in installing the head end. Make sure the cylinder head and piston rod are perpendicular to one another. Place your hands on top of the head and push downwards in a twisting motion. A small rubber mallet may be needed to assist during installation. Caution must be taken not to tear any seals. Seat the head end into the tube using the same process as seating the cap end.

**CAUTION:** KEEP FINGERS CLEAR BETWEEN HEAD AND TUBE DURING INSTALLATION.



5. Install the tie rods and tighten the tie rod nuts in an X pattern to avoid uneven loading. All threads must be torqued to the required specification in order to ensure functional reliability of the cylinder. For exact torque measurements, see the table on page 3.

## Testing

After the cylinder has been completely reassembled, it should be tested, either on a test bench or in the regular installation. The cylinder should be tested for cushioning, travel and leakage.

**CAUTION:** BE SURE AIR BLEED SCREW ON BOTH ENDS (ITEM 11) ARE COMPLETELY CLOSED.

### Cushioning:

1. Turn both cushioning valves completely in and then turn counterclockwise one (1) full turn.
2. Cycle cylinder a few times by alternating supply pressure to head and cap ports.
3. Apply supply pressure to the head port. Rod should retract, decelerate and may stop before completion of the stroke.
4. Apply supply pressure to the cap port. Rod should extend, decelerate and may stop before completion of the stroke.

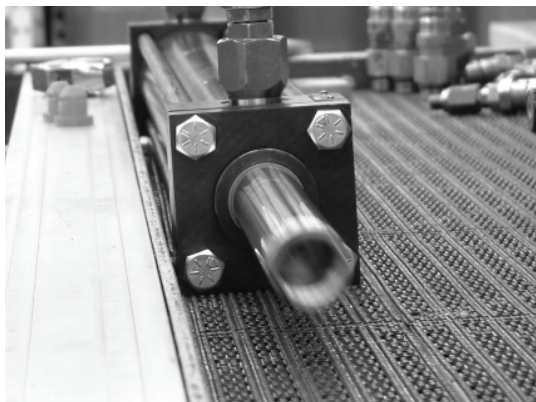

### Travel and Leakage

1. Apply supply pressure to the head port. Rod should retract smoothly without binding. Cylinder should retract, have less cushioning and make full stroke. Check leakage at the cap end, no leakage permitted. Check leakage around the rod bearing. No leakage permitted.
2. Apply supply pressure to the cap port. Rod should extend smoothly without binding. Cylinder should extend, have less cushioning and make full stroke. Check leakage at head end, no leakage permitted.

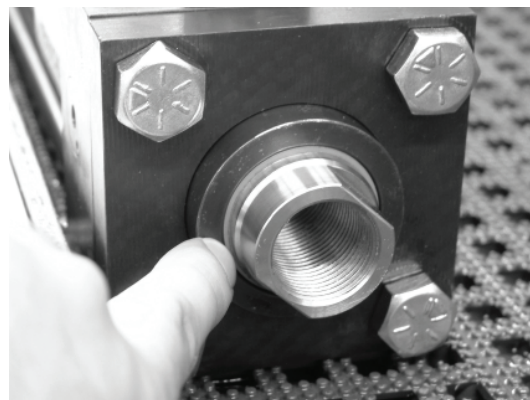

3. Return piston rod to retract position by applying supply pressure to head port. Remove supply pressure and install cylinder into service if satisfactory.

### Cushion Adjustment

Turn the cushioning valve clockwise to increase the amount of cushioning and counterclockwise to decrease cushioning. To obtain the most effective cushioning, final adjustment must be made while the cylinder is operating under normal conditions at normal operating pressure.

## Spare Parts

### Piston and Tube Seal Kits (Items 19e, f, g, h) ~ (Z10 Series prior to November 1, 2006)

Bore Ø (inches)	M	T *	F *	V *
1.000	R978006829	R978006849	R978006859	R978006839
1.500	R978006830	R978006850	R978006860	R978006840
2.000	R978006831	R978006851	R978006861	R978006841
2.500	R978006832	R978006852	R978006862	R978006842
3.250	R978006833	R978006853	R978006863	R978006843
4.000	R978006834	R978006854	R978006864	R978006844
5.000	R978006835	R978006855	R978006865	R978006845
6.000	R978006836	R978006856	R978006866	R978006846
8.000	R978006838	R978006858	R978006868	R978006848

### Rod Cartridge Seal Kits w/Rod Bearing (Items 19a, b, c, d and Item 16) †§ (Z10 Series prior to November 1, 2006)

Rod Ø (inches)	M	T *	F *	V *
0.50	R978009780	R978009782	R978009783	R978009781
0.625	R978006773	R978006801	R978006815	R978006787
1.000 (1.500" bore)	R978006774	R978006802	R978006816	R978006788
1.000 (2.000"-2.500" bore)	R978006775	R978006803	R978006817	R978006789
1.375 (2.000" bore)	R978006776	R978006804	R978006818	R978006790
1.375 (2.500"-3.250" bore)	R978006777	R978006805	R978006819	R978006791
1.750	R978006778	R978006806	R978006820	R978006792
2.000	R978006779	R978006807	R978006821	R978006793
2.500	R978006780	R978006808	R978006822	R978006794
3.000	R978006781	R978006809	R978006823	R978006795
3.500	R978006782	R978006810	R978006824	R978006796
4.000	R978006783	R978006811	R978006825	R978006797
4.500	R978006784	R978006812	R978006826	R978006798
5.000	R978006785	R978006813	R978006827	R978006799
5.500	R978006786	R978006814	R978006828	R978006800

M = Polyurethane seal system (standard)

T = Seal system for low friction applications (available)

F = Standard seal system for HFC (water glycol) (available)

V = Seal system for (phosphate ester) (available)

Note:

\* = not recommended for load holding applications

§ = CGT1 (double-rod) version requires two Rod Cartridge Kits

~ **Piston/Tube Seal Kits include:** one (1) double-acting piston seal; two (2) wear bands; two (2) o-rings and two (2) back-up rings

† **Rod Cartridge Seal Kits include:** one (1) double-lip wiper set; one (1) u-cup rod seal; one (1) rod bearing; one (1) back-up ring, one (1) o-ring

### Cushion Valve (Item 17)

Bore Size**	M, T, F	V
1-1/2", 2", 2-1/2"	R433015236	R978006424
3-1/4", 4", 5"	R433016568	R978006436
6", 8"	R433023258	R978006437

\*\* adjustable cushions are not available on 1" bore size cylinders.

## Spare Parts

### Piston and Tube Seal Kits (Items 19e, f, g, h) ~

(Z11 Series after to November 1, 2006)

Bore Ø (inches)	M	T *	F *	V *
1.000	R978029042	R978029064	R978029064	R978029053
1.500	R978029043	R978029065	R978029065	R978029054
2.000	R978029044	R978029066	R978029066	R978029055
2.500	R978029045	R978029067	R978029067	R978029056
3.250	R978029046	R978029068	R978029068	R978029057
4.000	R978029047	R978029069	R978029069	R978029058
5.000	R978029048	R978029070	R978029070	R978029059
6.000	R978029049	R978029071	R978029071	R978029060
7.000	R978029051	R978029072	R978029072	R978029062
8.000	R978029052	R978029073	R978029073	R978029063

### Rod Cartridge Seal Kits w/Rod Bearing (Items 19a, b, c, d and Item 16) †§

(Z11 Series after to November 1, 2006)

Rod Ø (inches)	M	T *	F *	V *
0.50	R978009780	R978009782	R978009783	R978009781
0.625	R978006773	R978032046	R978032046	R978032045
1.000 (1.500" bore)	R978006774	R978021088	R978021088	R978021097
1.000 (2.000"-2.500" bore)	R978006775	R978029158	R978029158	R978029154
1.375 (2.000" bore)	R978006776	R978021089	R978021089	R978021098
1.375 (2.500"-3.250" bore)	R978006777	R978021090	R978021090	R978021099
1.750	R978006778	R978021091	R978021091	R978021100
2.000	R978006779	R978021092	R978021092	R978021101
2.500	R978006780	R978021093	R978021093	R978021102
3.000	R978006781	R978021094	R978021094	R978021103
3.500	R978006782	R978021095	R978021095	R978021104
4.000	R978006783	R978021096	R978021096	R978021105
4.500	R978006784	R978029159	R978029159	R978029155
5.000	R978006785	R978029160	R978029160	R978029156
5.500	R978006786	R978029161	R978029161	R978029157

**M** = Polyurethane seal system (standard)

**T** = Seal system for low friction applications (available)

**F** = Standard seal system for HFC (water glycol) (available)

**V** = Seal system for (phosphate ester) (available)

#### Note:

\* = not recommended for load holding applications

§ = CGT4 (double-rod) version requires two Rod Cartridge Kits

~ **Piston/Tube Seal Kits include:** one (1) double-acting piston seal;  
two (2) wear bands; two (2) o-rings and two (2) back-up rings

† **"M" Rod Cartridge Seal Kits include:** one (1) double-lip wiper set; one (1) u-cup rod seal; one (1) rod bearing; one (1) back-up ring, one (1) o-ring

"**T, F, V**" rod cartridge seal kit includes: one (1) excluder wiper, two (2) step seal rod seals, one (1) rod bearing, one (1) back-up ring, one (1) o-ring

### Cushion Valve (Item 17)

Bore Size**	M, T, F	V
1-1/2", 2", 2-1/2"	R433015236	R978006424
3-1/4", 4", 5"	R433016568	R978006436
6", 8"	R433023258	R978006437

\*\* adjustable cushions are not available on 1" bore size cylinders.

## Spare Parts

### Tube (Item 2)\*

Bore Size	Part No.
1.000	R978007816
1.500	R978007817
2.000	R978007818
2.500	R978007819
3.250	R978007820
4.000	R978007821
5.000	R978007822
6.000	R978007823
8.000	R978007824

### Tie Rods (Item9)\*

Bore Size	MX0, MS2, MT1 MT2, MP1	MF1, MF5	MF2, MF6	MX1	MX2	MX3
1.000	R978008229	R978010028	R978010035	R978010042	R978010050	R978010058
1.500	R978008230	R978010029	R978010036	R978010043	R978010051	R978010059
2.000	R978008231	R978010030	R978010037	R978010044	R978010052	R978010060
2.500	R978008232	R978010031	R978010038	R978010045	R978010053	R978010061
3.250	R978008233	R978010032	R978010039	R978010046	R978010054	R978010062
4.000	as above	as above	as above	as above	as above	as above
5.000	R978008234	R978010033	R978010457	R978010047	R978010055	R978010063
6.000	R978008235	R978010034	R978010041	R978010048	R978010056	R978010064
8.000	R978008236	n/a	n/a	R978010049	R978010057	R978010065

### Piston and Rod Assemblies (Items 3, 6, 10, 14, 19e, f, g, h)\*

Consult Factory for Part Numbers and Pricing.

\* specify complete cylinder part number and stroke length when ordering.

Bosch Rexroth Corp.  
Industrial Hydraulics  
2315 City Line Road  
Bethlehem, PA 18017-2131  
USA  
Telephone (610) 694-8300  
Facsimile (610) 694-8467  
www.boschrexroth-us.com

© 2004 Bosch Rexroth Corporation

All rights reserved. Neither this document nor any part of it may be reproduced, duplicated, circulated or disseminated, whether by copy, electronic format or any other means, without the prior consent and authorization of Bosch Rexroth Corporation.

The data and illustrations in this brochure/data sheet are intended only to describe or depict the products. No representation or warranty, either express or implied, relating to merchantability or fitness for intended use, is given or intended by virtue of the information contained in this brochure/data sheet. The information contained in this brochure/data sheet in no way relieves the user of its obligation to insure the proper use of the products for a specific use or application. All products contained in this brochure/data sheet are subject to normal wear and tear from usage.

Subject to change.